

Fracture studies on polypropylene

G. L. A. SIMS*

Department of Polymer and Fibre Science, University of Manchester Institute of Science and Technology, Sackville Street, Manchester, UK

Measurements of fracture surface energy have been made on polypropylene in the undrawn state and at different states of orientation over the temperature range -60 to 60°C . Tear tests were employed and it was found that the fracture surface energy of unoriented material was of the order of 10^4 to 10^5 J m^{-2} . As orientation (represented by birefringence) increased, the fracture surface energy decreased by a factor of approximately 100 at room temperature but this factor was found to decrease with decreasing temperature. For all degrees of orientation, the fracture surface energy increased with increasing temperature in the range -60 to 60°C .

Scanning electron microscope studies showed a direct relation between the crack tip diameter and the fracture surface energy of unoriented specimens. From comparable studies on the tearing of rubber, Thomas has interpreted such a relationship as implying that the high values of fracture surface energy arise from the energy required to deform the material in the crack tip up to the breaking point. On this basis the reduction in fracture surface energy with increase in orientation may be regarded as being due to the associated diminution of the crack tip diameter. This interpretation is substantiated by direct measurements of crack tip diameter for specimens of intermediate and high orientation. Further microscopic studies of fracture surfaces indicate three modes of fracture which have been correlated with the appearance of the crack tip and tend to occur in certain ranges of birefringence.

1. Introduction

Fracture studies of oriented polypropylene are of interest theoretically, since drawn crystalline polymers are more highly anisotropic in properties than drawn glassy polymers, and practically in fibrillation processes. It is considered that an important parameter with regard to fibrillation is the fracture surface energy for crack propagation parallel to the direction of preferred orientation. This parameter is studied as a function of orientation, test temperature (-60 to $+60^{\circ}\text{C}$) and crack tip diameter.

1.1. The Griffith theory

The Griffith theory [1] was originally formulated for brittle elastic solids of the glassy type. This theory supposes that a crack will propagate only if the change in total free energy in doing so is negative or zero. This leads to the criterion for crack propagation,

$$\left(\frac{\partial W}{\partial c}\right)_t = -\gamma \left(\frac{\partial A}{\partial c}\right) = -2\gamma t \quad (1)$$

where W is the elastically stored energy in the specimen at length l , γ is the surface energy per unit area, $(\partial A/\partial c)$ is the increase in free surface area due to an increase in crack length ∂c , and t is the thickness of the specimen. When the theory is applied to materials other than inorganic glasses, large discrepancies are found between observed and theoretical surface energies [2]. Orowan [3] proposed that γ consisted of the sum of two contributions γ_s , the true surface energy and γ_p , the energy dissipated in plastic flow processes. γ is then redefined as the fracture surface energy per unit area and is not a true constant of the material.

According to the Griffith theory, the fracture stress in tension is inversely proportional to the square root of the crack length. This has been

* Present address: Sun Printers Limited, Whippendell Road, Watford, Herts.

established for glass [1] and metals [4]. Berry [5, 6] has shown that the prediction also holds good for the glassy polymers PMMA and polystyrene. The theoretical surface energy for these materials based on values of intermolecular forces was calculated to be approximately 0.45 J m^{-2} yet the experimental values obtained were $2 \times 10^2 \text{ J m}^{-2}$ and $1.7 \times 10^3 \text{ J m}^{-2}$ for PMMA and polystyrene, respectively. Berry attributed the discrepancy to energy dissipated in local plastic deformation at the crack tip [7]. Rivlin and Thomas [8] obtained values of γ for rubbers in the region of 10^3 to 10^4 J m^{-2} . These values of γ have been shown to be equal to the energy required to produce the high extension of the material in the crack tip [9].

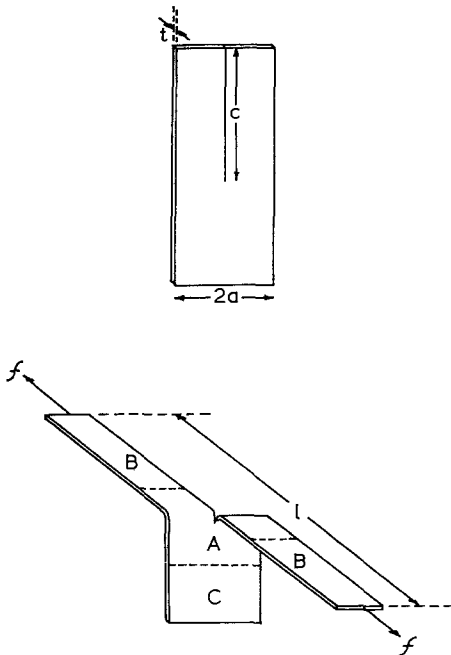

Figure 1 Trouser leg tear test specimen.

1.2. Tear tests

Anderton and Treloar [10] produced an analysis of "trouser-leg" test pieces (Fig. 1) avoiding the assumption of reversibility in the fracture process. Considering the trouser-leg specimen to consist of three distinct regions of strain; A, inhomogeneous strain; B, uniform strain, and C, an unstrained region, the following relationship is derived,

$$\gamma = \frac{\lambda f}{t} - \frac{W_\lambda A_0}{2t} \quad (2)$$

where λ is the extension ratio in the uniformly strained regions B, f is the measured force to produce tearing, W_λ is the stored energy density corresponding to an extension ratio λ , and A_0 is the unstrained cross-sectional area of the uncut specimen. When the strain in the regions B is so small that $W_\lambda A_0/2t$ is negligible compared with $\lambda f/t$, a condition that may usually be achieved by increasing the width of the specimen, since $\lambda \approx 1$, Equation 2 reduces to

$$\gamma \approx f/t. \quad (3)$$

Greensmith and Thomas [11] found that although the theoretical treatment assumes no deviation in the direction of the tear propagation from the central axis of the specimen, the results are not sensitive to small variations from this condition.

1.3. The significance of crack tip diameter

Thomas [9] derived an approximate relationship between γ and the crack tip diameter d at the point of rupture

$$2\gamma \approx E \cdot d \quad (4)$$

where E is the strain energy density required to bring the material up to the breaking point. Greensmith [12] considered Equation 4 to be applicable to continuous tearing of rubber and obtained reasonably good agreement between $2\gamma/d$ and E . Anderton and Treloar [10] measured instantaneous values of both γ and the crack tip diameter of polyethylene film during the course of tearing. Reasonable agreement was obtained between observed and calculated values of the crack tip diameter over a range from 0.05 to 0.31 mm.

1.4. The dependence of γ on orientation

For crack propagation parallel to the direction of orientation in a cleavage specimen, the fracture surface energies of PMMA and polystyrene were found to decrease with increasing orientation [13, 14]. Miller *et al.* [15] studied the cleavage fracture of poly(vinyl chloride), parallel to the direction of orientation, and observed two modes of fracture which gave characteristic fracture surfaces. In studies of the tearing behaviour of biaxially oriented poly(ethylene terephthalate) film [16], it was found that γ decreased as the direction of tearing approached the direction of maximum orientation. Tear-tests were also performed by Anderton and Treloar [10] on polyethylene film at different extents of orienta-

tion. It was found that the value of γ for the highly oriented material was smaller by a factor of about 100 compared with the value for isotropic polyethylene. Cleavage tests were also performed which gave excellent agreement with tear-test results.

1.5. The dependence of γ on temperature

Various workers [17-20] have studied the dependence of γ on temperature for glassy polymers. In general, over varying ranges up to 50°C, it is found that γ decreases with increasing temperature. In contrast, studies on metals [21, 22] show that γ decreases with decreasing temperature and approaches the theoretical value of surface free energy at low temperatures. No comparable work has been performed on semi-crystalline polymers. The mechanism is difficult to predict due to the complexity of crystallites in semi-crystalline polymers compared with the crystallites in metals [23].

2. Experimental

2.1. Sample preparation

I.C.I. grade Propathene G.W.E.21 polypropylene was supplied in granule form. This is a specific extrusion grade of polymer having a melt flow index of 3 at 230°C under an applied load of 2.16 kg.

In order to obtain a homogeneously moulded sheet, a standard charge of approximately 200 g was milled on an electric two-roll mill for 25 min using roll temperatures of 155 and 170°C. The sample was then drawn off in crepe form in thicknesses of about 2 mm. 25 g charges of the milled sheets were then moulded into sheets approximately 0.3 mm thick in the following manner. Moulding was carried out by placing the charge between two polished stainless steel plates coated with a thin film of silicone oil release agent. The plates were then transferred to a Losca press, the temperature of both platens being 210°C. A slight positive pressure was exerted, then, after 1 min, the pressure was increased incrementally to 715 psi* over a period of 2 min. This pressure was maintained for a further 5 min and thence while the platens were rapidly water-cooled to 25°C. To ensure sample uniformity and the relaxation of strains incurred by the moulding technique, the moulded sheets were annealed between mild steel plates at 130°C for 16 h. Samples from these sheets, which showed no birefringence, were used to determine

*10³ psi \equiv 6.89 N mm⁻².

the fracture surface energy of unstrained material.

Specimens of length 250 mm and width 60 mm were cut from the annealed sheet and drawn to varying degrees of orientation. Uniformity of drawing was assessed by marking a grid system on the unstrained sample. The drawing was carried out in a heating chamber attached to a machine adapted from a screw cutting lathe. Air in the chamber was circulated by means of two fans and the temperature could be controlled to $\pm 2^\circ\text{C}$. One grip was fixed and the other was attached to the moving saddle of the lathe. Drawing commenced after allowing the sample 45 min to attain temperature equilibrium. After drawing, the sample was held in the final strained state until the temperature had fallen to 25°C. The samples were drawn at 12% min⁻¹ to different draw ratios at 130°C. Oriented samples gave birefringence values from approximately 0.02 at low draw ratios to 0.04 for draw ratios of about 15:1. Owing to the necking tendency of polypropylene, birefringence values in the range 0 to 0.02 could not be obtained by the above method. Samples in this range were obtained by annealing oriented specimens in the stress-free state at 161°C for varying lengths of time up to 90 min. Reduction in birefringence was accompanied by a corresponding decrease in the measured value of draw ratio.

Samples in the range 0.02 to 0.03 were obtained by the two techniques, i.e. (1) by drawing to a particular draw ratio or (2) by drawing to a higher draw ratio and annealing. Results taken from both types of sample are included in subsequent birefringence-draw ratio, and fracture surface energy-birefringence data.

2.2. Measurement of birefringence

There is no standard method of measuring the degree of molecular orientation of the drawn polymer. Measurements of birefringence, i.e. the difference of refractive indices in the longitudinal and transverse directions have been used as an arbitrary standard of reference. The birefringence of each sample was measured by means of a Babinet compensator.

2.3. Determination of the fracture surface energy

All measurements were carried out on trouser-leg specimens (Fig. 1) using an Instron Universal force-displacement recorder. The test specimens

were cut from unstrained and oriented film (in which case the specimens were cut parallel to the draw direction) having approximate dimensions of 70 mm long \times 20 mm wide and 0.05 to 0.35 mm thick. Initial crack lengths of about 25 mm were introduced into the specimens along the median of the specimen in the length direction. This was effected by inserting a razor blade into the specimen with its edge perpendicular to the plane of the film. This technique was used in order to obtain a sharp and relatively reproducible crack tip. The fracture surface energy for propagation was calculated from the average steady tearing force and the thickness of the specimen using Equation 3. All tests were carried out at a cross-head speed of 5 mm min⁻¹. The fracture surface energy was studied as a function of birefringence under controlled conditions of 20°C and 50% relative humidity. Similar studies were carried out at temperatures in the range -60 to +60°C using an Instron Environmental chamber. Testing at temperatures other than 20°C involved maintaining the specimens at the test temperature for at least 30 min before testing. For temperatures above 20°C the resistance heaters in the walls of the chamber were used in conjunction with a fan for air circulation. Temperatures below ambient were achieved by forcing liquid nitrogen vapour into the chamber by careful control of nitrogen gas pressure.

2.4. Measurement of crack tip diameters and observation of fracture surfaces

Values of γ were determined for unoriented polypropylene at various points on the force-displacement curve up to the point at which continuous tearing occurred. The aim was to determine the crack tip diameter at various values of the fracture surface energy and test the validity of Equation 4 for unstrained polypropylene specimens. Crack tip diameters were measured with a scanning electron microscope. For this purpose the crack tip and surrounding material were cut from the torn specimen and mounted on an aluminium stub. The sample was coated with a thin layer of silver (just sufficient to prevent charging up in the electron beam) by vacuum metallization in an Edwards Vacuum Coating Unit. The sample was then viewed in a Cambridge Scanning Electron Microscope and micrographs of the crack tip were taken perpendicular to the plane of the film at the crack tip. In some instances further adjustments were made to take into account distortion of the

material in the vicinity of the crack tip caused by local plastic deformation occurring in the tearing process. Studies were also made of crack tip diameters in oriented specimens and of the appearance of fracture surfaces at varying extents of orientation.

3. Results and discussion

3.1. The effect of orientation on the fracture surface energy

The effect of varying extents of orientation on the value of the fracture surface energy is shown for test temperatures of 60, 20, 0, -20 and -60°C in Figs. 2 to 6 respectively. Fig. 3 shows the value of γ to decrease from 6.09×10^4 J m⁻² for unoriented material to approximately 0.9×10^3 J m⁻² at a birefringence of 0.036. This reduction in the value of the fracture surface energy at room temperature is similar in magnitude to the reductions observed by Anderton and Treloar [10] who studied polyethylene, Broutmann and McGarry [13] who studied polystyrene, and Miller *et al.* [15] in studies on poly(vinyl chloride). It might at first seem logical to attribute the cause of the diminution of the fracture surface energy with increasing extents of orientation to the progressive increase in alignment of the polymer

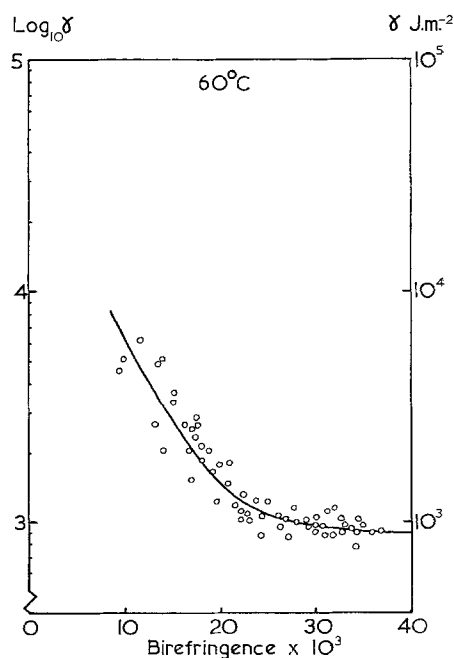

Figure 2 Fracture surface energy versus birefringence. Test temperature 60°C.

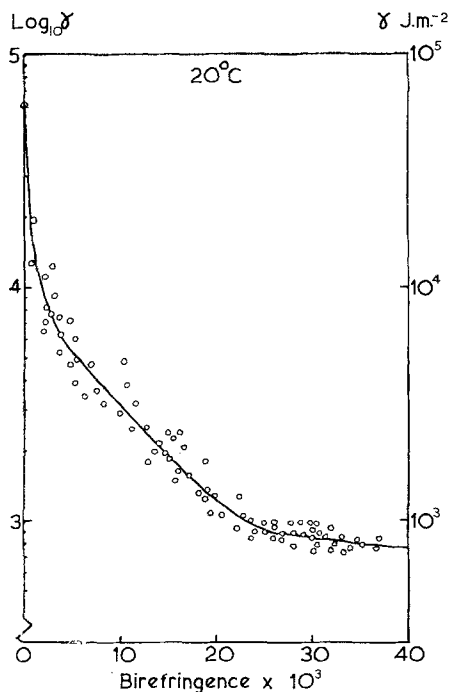

Figure 3 Fracture surface energy versus birefringence. Test temperature 20°C.

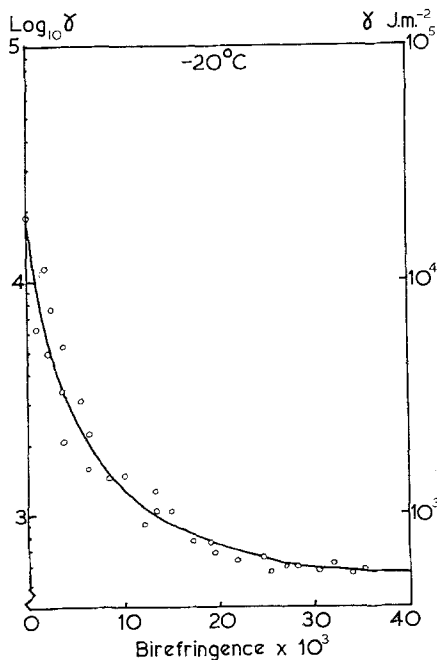

Figure 5 Fracture surface energy versus birefringence. Test temperature -20°C.

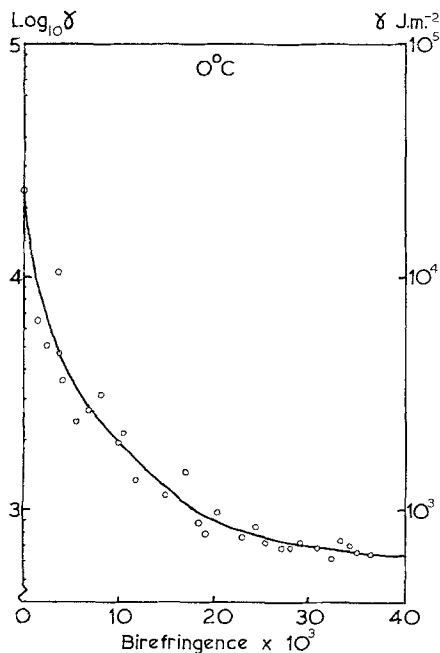

Figure 4 Fracture surface energy versus birefringence. Test temperature 0°C.

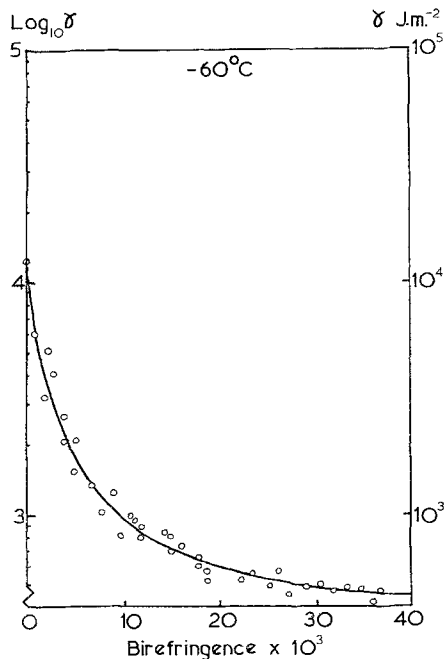

Figure 6 Fracture surface energy versus birefringence. Test temperature -60°C.

molecules as the degree of orientation increases. Owing to the geometry of the system, tearing parallel to the direction of maximum orientation

would require fewer bonds to be ruptured as the orientation increases. This concept is entirely misleading since the total contribution to the fracture surface energy arising from this effect is

negligible, considering the magnitudes of 10^3 to 10^4 J m⁻² obtained. It is proposed that the orientation reduces the amount of plastic work associated with the fracture process and hence reduces the fracture surface energy.

It is noticeable that the value of the fracture surface energy varies only slightly with orientation for values of birefringence in excess of 0.022. This corresponds to the region of neck-down when polypropylene is drawn. Peterlin and Balta-Calleja [24] studied the small-angle X-ray scattering of drawn polypropylene film and showed that the usual spherulitic structure changes progressively to a completely fibrous form in the highly drawn necked regions. This is proposed as the explanation why only small changes in fracture surface energy are observed in samples taken from the neck region.

One important consideration is the method of preparation of samples with low birefringence values. Annealing drawn specimens at 161°C for varying lengths of time affects the crystallinity and microstructure of the film as well as having the desired effect of reducing birefringence [25-27]. Since a polymer crystal is a birefringent entity, any significant change in crystallinity of oriented material should be detected by an increase in birefringence. Fig. 7 shows the relation between birefringence and draw ratio obtained in the present studies. This graph is very similar in form to that obtained by Schael [28] whose work did not involve annealing. This suggests that the annealing procedure adopted in this work does not appreciably affect the crystallinity. Changes in microstructure have not been assessed though they may account for the decrease in reproducibility of γ values in the birefringence range 0 to 0.022.

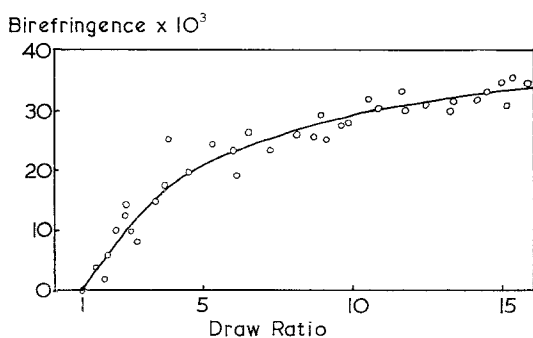

Figure 7 Birefringence versus draw ratio for polypropylene.

Samples of similar birefringences in the range 0.02 to 0.03, prepared by annealing or straight drawing techniques (as described in Section 2.1), give similar values of birefringence and fracture surface energy. This is further evidence to suggest that the annealing procedure does not appreciably affect crystallinity, at least over this range of birefringence.

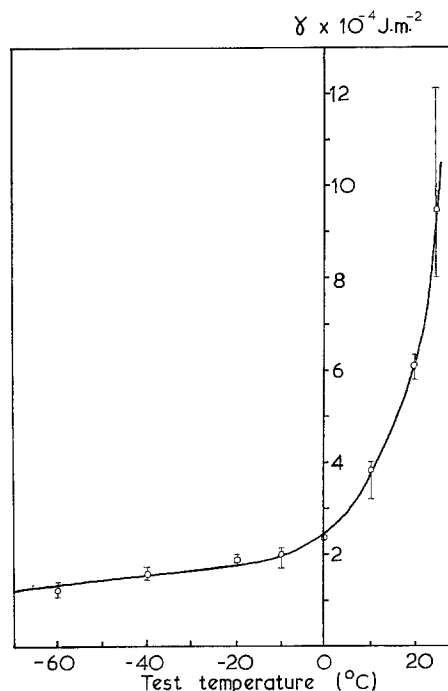

Figure 8 Fracture surface energy versus test temperature for unstrained polypropylene.

3.2. The dependence of fracture surface energy on test temperature

Fig. 8 shows the dependence of fracture surface energy on the test temperature for unstrained polypropylene. From -60 to -10°C the fracture surface energy changes approximately linearly with temperature. Above 10°C the value of γ increases more rapidly with increasing test temperature. It is interesting to note that this transition compares with the glass transition temperature of polypropylene, measured statistically, quoted in the literature [29] as -10 and -18°C . Fig. 9 shows the effect of test temperature on the magnitude of γ at birefringence values of 0.010, 0.020, 0.030 and 0.040. It is noticeable that as orientation increases, the transition becomes less clearly defined.

Figs. 8 and 9 show that all extents of orientation γ increases with increasing temperature and

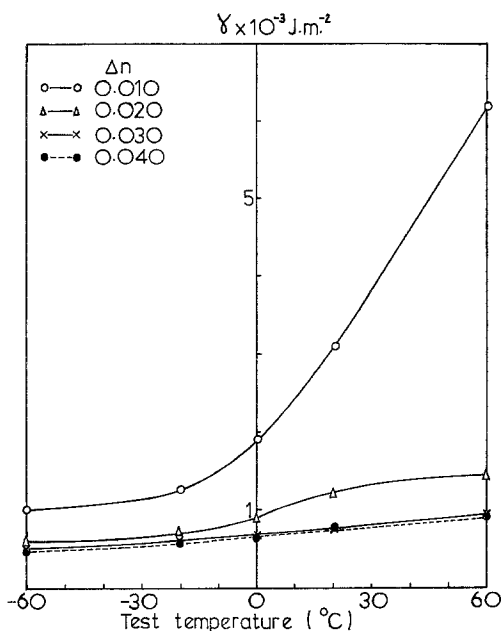

Figure 9 Fracture surface energy versus test temperature for polypropylene strained to different extents.

thus polypropylene shows a similarity to the fracture surface energy/temperature behaviour of metals. This is thought to be due to the semi-crystalline structure of the polymer and tends to indicate that the proportion of crystalline material would influence the fracture behaviour of polymers.

3.3. The relationship between fracture surface energy and crack tip diameter of unoriented material

Data shown in Figs. 2 to 6, 8 and 9 were calculated on the basis of the steady tearing force

TABLE I

$\gamma \times 10^{-4} \text{ (J m}^{-2}\text{)}$	$d_{\text{measured}} \text{ (mm)}$	$d_{\text{calculated}} \text{ (mm)}$
2.56	0.208	0.264
2.80	0.216	0.289
3.14	0.214	0.324
3.50	0.411	0.361
3.53	0.376	0.364
3.92	0.285	0.404
4.00	0.291	0.412
4.71	0.473	0.486
5.10	0.379	0.526
5.43	0.488	0.560
5.72	0.538	0.590
5.85	0.532	0.603
5.98	0.515	0.616
6.06	0.568	0.625

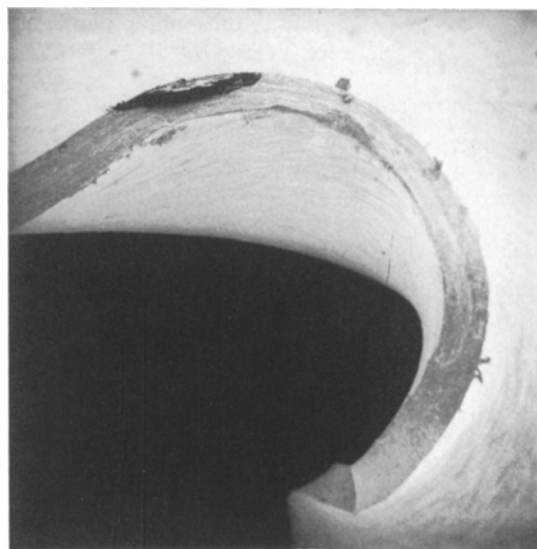

Figure 10 Scanning electron micrograph of a crack tip of unstrained polypropylene fractured under steady tearing conditions, $\times 70$.

derived from curves of the type shown in Fig. 15a and b. The fracture surface energy so derived is that for propagation. However, tearing initiates at a much lower force approximately 0.2 kgf in Fig. 15a.

Equation 3 is applicable, in principle, to any point on the force-displacement curve. It is therefore suggested that γ increases continuously from $\gamma_{\text{initiation}}$ up to the point at which steady or constant tearing occurs. If Equation 4 is valid, the diameter of the crack tip must increase accordingly up to constant tearing conditions. The value of E was obtained by tensile experiments carried out at a rate of strain of $7\% \text{ min}^{-1}$. Ten such experiments were performed giving a mean value of 0.194 J mm^{-3} for the energy per unit volume required to bring the specimen up to the breaking point. The experimental error in this estimation was $\pm 18\%$.

Fig. 10 shows the crack tip of a specimen which had reached continuous tearing, corresponding to a fracture surface energy of $6.06 \times 10^4 \text{ J m}^{-2}$. The crack tip diameter is easily assessed from a micrograph of this type. However, as the value of γ decreases, the measurement becomes more difficult. At values of γ below $2.5 \times 10^4 \text{ J m}^{-2}$ the crack tip is not easily accessible for viewing with the result that measurement cannot be made with any degree of assurance. Table I gives the comparison of crack tip diameters, measured and calculated,

for different values of γ . Reasonable agreement is obtained between observed and calculated values.

It must be emphasized that errors in the measurement of the diameter arise from two sources. Firstly, the physical estimation of crack tip diameters from micrographs gave an error of approximately $\pm 3\%$. However, the most critical source of error involved was the adjustment of the sample by tilting and rotating to obtain the correct viewing angle. One sample was placed a number of times in the specimen chamber of the scanning electron microscope in a variety of positions. Adjustments were then made until the crack tip appeared on the screen in such a way that the sample was viewed normally to the plane of the film in the tip. This procedure was crucial to the measurement of the tip diameter. Ten readings gave values of crack tip diameter ranging from 0.486 to 0.568 μm . It is suggested that the highest measured value of the tip diameter will be closest to the true value since the diameter will appear smaller if viewed at any angle other than normal to the plane of the film in the crack tip. In practice this is sometimes impossible to achieve due to distortion of the specimen. It is, therefore, inferred that measured values of the crack tip are probably in error, being smaller than the true value. Results indicate that Equation 4 holds extremely well for the fracture of unoriented polypropylene. This suggests that the value of γ of polypropylene is associated with the energy required to deform the material in the crack tip.

3.4. Observation of oriented crack tips and fracture surfaces

Specimens of intermediate orientation ($\Delta n = 14.97 \times 10^{-3}$), and high orientation ($\Delta n = 27.13 \times 10^{-3}$), corresponding to fracture surface energies of $2.21 \times 10^3 \text{ J m}^{-2}$ and $0.87 \times 10^3 \text{ J m}^{-2}$ respectively, were torn in the manner previously described. The material in the vicinity of the crack tip was then mounted and observed by scanning electron microscopy as outlined in Section 2.4. In both cases it was evident that void formation preceded fracture. The crack tip diameter of oriented material is less clearly defined than that of an unoriented specimen and notably very much smaller. The crack tip diameters for specimens of intermediate and high orientation were estimated to be 0.0005 mm, and 0.0003 mm, respectively, although no attempt

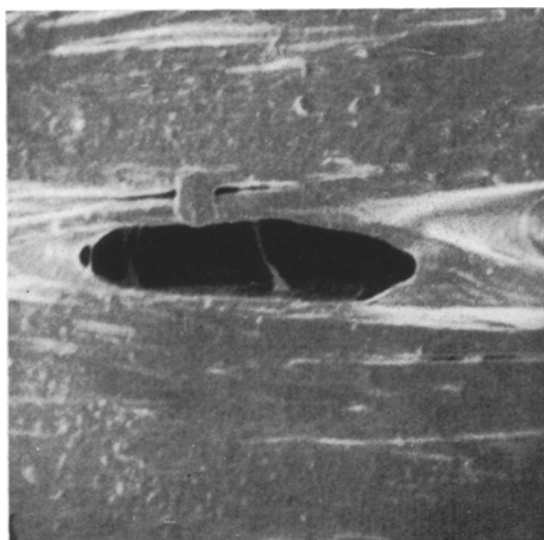

Figure 11 Micrograph of a void preceding the crack tip of a polypropylene specimen intermediate orientation, $\times 1780$.

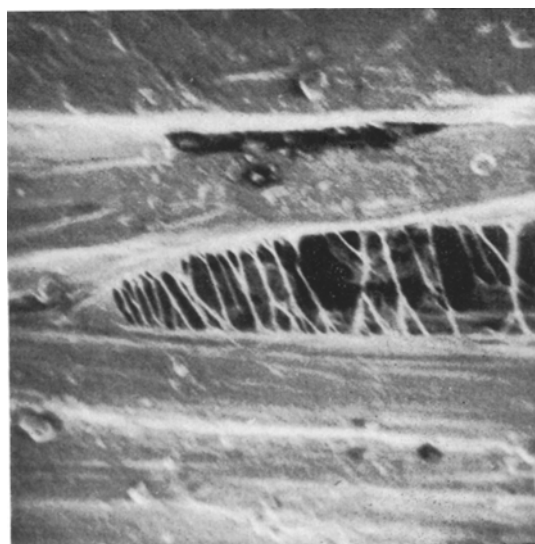

Figure 12 Void preceding the crack tip of a specimen of high orientation, $\times 3440$.

was made to assess the experimental error in this estimation.

Fig. 11 shows a typical void ahead of the crack tip in specimens of intermediate orientation. Two or three microfibrils are observed to bridge the longitudinal void. Fibre cross-overs are evident in the crack tip of highly oriented specimens and the appearance of the void preceding the crack tip (Fig. 12) is markedly

different. A large number of microfibrils are observed laterally bridging the longitudinal void. There is a marked similarity between voids preceding fracture (Fig. 12) and those observed by Peterlin [30] in studies on plastic deformation of polypropylene. Scanning electron micrographs of specimens fractured from the neck region all show similar void formation ahead of the crack tip which supports the findings of Peterlin and Balta-Calleja [24] on the nature of the microstructure in the neck region. Fig. 11 also shows microfibrils bridging the void but to a lesser extent. As only two or three microfibrils are observed bridging the void, it is assumed that a birefringence of 14.97×10^{-3} corresponds to the onset of fibre structure. The proportion of fibre structure gradually increases up to birefringence values corresponding to the neck region where the spherulite structure has completely broken down.

Fracture surfaces were also observed at varying extents of orientation. It is found that surface roughness increases in severity as orientation increases and that the appearance of the fracture surface may be characterized by three general types. A relatively smooth surface predominates for specimens of low birefringence values of approximately $\Delta n = 10.0 \times 10^{-3}$. Between the birefringence values of approximately 10.0×10^{-3} and 20.0×10^{-3} the predominant feature of the fracture surface is the considerable amount of plastic flow as shown in Fig. 13. Since void formation precedes the crack tip of the material, the apparently gross plastic deformation may be observed to arise by straining the material between the crack tip and the void up to the breaking point. Successive breaking of this material as the crack advances gives the characteristic surface features shown in Fig. 13. Highly oriented material, corresponding to a birefringence of 27.13×10^{-3} revealed a fracture surface of an entirely fibrillar nature as shown in Fig. 14. The appearance of the fracture surface in this micrograph is typical of all specimens taken from the neck region and supports the interpretation of the mechanism of fracture of highly oriented polypropylene discussed above.

Although the three different types of fracture surface have been quoted as applying to the ranges of birefringence of 0 to 10.0×10^{-3} , 10.0×10^{-3} to 20.0×10^{-3} and 20.0×10^{-3} upwards, it must be noted that these values are not clearly defined. The transition between relatively smooth and plastic flow types of



Figure 13 Micrograph of the fracture surface of a polypropylene specimen of birefringence $0.015, \times 830$.



Figure 14 Fracture surface of a polypropylene specimen taken from the neck region, $\times 1620$.

fracture surface is rather difficult to distinguish since the process is gradual rather than sharply defined. The transition between the plastic flow type and fibrillar fracture surfaces is more marked though one or other or a combination of both types is observed between the approximate birefringence limits of 17×10^{-3} and 22×10^{-3} .

Fig. 15 shows typical force-displacement curves of (a) unoriented and (b) highly oriented

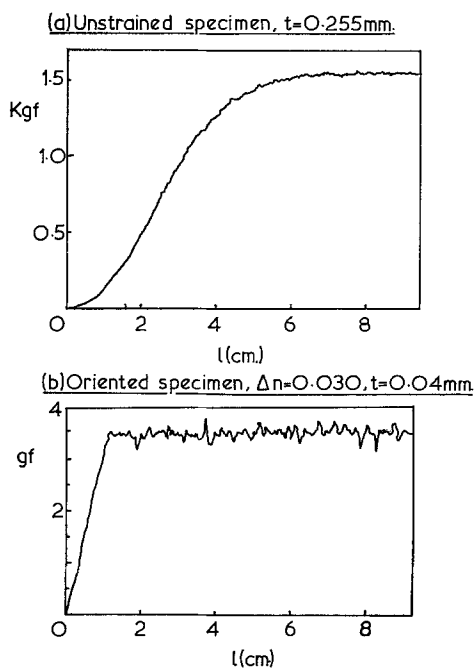

Figure 15 Typical tearing curves for (a) unstrained and (b) highly oriented polypropylene.

polypropylene. The regularity of the tearing curve decreases steadily with increasing birefringence. This phenomenon may be explained with reference to the appearance of the fracture surfaces. A comparatively featureless fracture surface is observed on an unoriented specimen, corresponding to a smooth tearing curve as depicted in Fig. 15a. As the orientation increases, so the mechanism of fracture changes to include void formation. Each element of material is strained until rupture occurs, thus the regularity of the tearing curve decreases with increasing orientation. The crack tip of a highly oriented specimen shows many fibre cross-overs and microfibrils are present in the vicinity of the crack tip. As these are being drawn the tearing force rises; when any fibres break or are pulled out of the matrix, the tearing force drops. This effect is continuously occurring at the crack tip accounting for the erratic nature of the force-displacement curves typified by Fig. 15b.

4. Conclusions

The fracture surface energy of polypropylene decreases with increasing orientation. This is assumed to be due to the progressive diminution of the crack tip diameter which has been shown to occur and which in turn may be caused by the

preorientation restricting plastic flow prior to fracture.

At all extents of orientation, the fracture surface energy increases with increasing test temperature in the range -60 to $+60^{\circ}\text{C}$. The magnitude of γ of unoriented specimens increases rapidly above the glass transition temperature but this effect diminishes as orientation is increased. These observed phenomena are considered to be due to an increase in gross inelastic deformation as the temperature is raised above the glass transition temperature.

Scanning electron microscope studies have correlated γ , the crack tip diameter and the energy to bring unit volume of the material up to the breaking point. In this work the correlation has been studied for unstrained polypropylene only. Further SEM studies indicate three modes of failure dependent on the degree of orientation and that above a birefringence of approximately 0.015, fracture is accompanied by void formation.

Acknowledgement

Acknowledgement is made to Professor L. R. G. Treloar for his supervision and encouragement throughout the work; to the Science Research Council for financial support during the period of the research; and to J. L. Spencer-Smith and other members of Lambeg Industrial Research Association for helpful discussions.

References

1. A. A. GRIFFITH, *Phil. Trans. Roy. Soc. A* **221** (1920) 163.
2. E. OROWAN, *Rep. Prog. Phys.* **12** (1948-49) 185.
3. *Idem*, *Welding J. Res. Suppl.* **34** (1955) 157s.
4. D. K. FELBECK and E. OROWAN, *ibid* **34** (1955) 510s.
5. J. P. BERRY, *J. Polymer Sci.* **50** (1961) 107.
6. *Idem*, *ibid* **50** (1961) 313.
7. *Idem*, *J. Appl. Polymer Sci.* **33** (1962) 1741.
8. R. A. RIVLIN and A. G. THOMAS, *J. Polymer Sci.* **10** (1953) 291.
9. A. G. THOMAS, *ibid* **18** (1955) 177.
10. G. E. ANDERTON and L. R. G. TRELOAR, *J. Mater. Sci.* **6** (1971) 562.
11. H. W. GREENSMITH and A. G. THOMAS, *J. Polymer Sci.* **18** (1955) 189.
12. H. W. GREENSMITH, *J. Appl. Polymer Sci.* **3** (1960) 183.
13. L. J. BROUTMAN and F. J. MCGARRY, *ibid* **9** (1965) 609.
14. J. W. CURTIS, *J. Phys. D. (Appl. Phys.)* **3** (1970) 1413.

15. L. E. MILLER, K. E. PUTTICK and J. G. RIDER, *J. Polymer Sci. C* **33** (1971) 13.
16. K. N. ORBRYADCHIKOV and V. V. KOVRIGA, *Plast. Massy*. **11** (1969) 65.
17. J. P. BERRY, *J. Polymer Sci.* **A1** (1963) 993.
18. L. J. BROUTMAN and F. J. MCGARRY, *J. Appl. Polymer Sci.* **9** (1965) 589.
19. J. J. BENBOW, *Proc. Phys. Soc.* **78** (1961) 970.
20. N. L. SVENSSON, *ibid* **77** (1961) 876.
21. J. J. GILMAN, *J. Appl. Phys.* **31** (1960) 2208.
22. D. HULL, P. BEARDMORE and A. P. VALENTINE, *Phil. Mag.* **12** (1965) 1021.
23. J. P. BERRY, *J. Polymer Sci.* **C3** (1963) 91.
24. A. PETERLIN and F. J. BALTA-CALLEJA, *J. Appl. Phys.* **40** (1969) 4238.
25. R. G. CRYSTAL and D. HANSEN, *ibid* **38** (1967) 3103.
26. S. G. TURLEY and H. KESKKULA, *J. Appl. Polymer Sci.* **9** (1965) 2693.
27. L. B. MORGAN and P. G. STERN, *Polymer* **9** (1968) 375.
28. G. W. SCHAEEL, *J. Appl. Polymer Sci.* **12** (1968) 903.
29. L. E. NIELSEN, "Mechanical Properties of Polymers", (Reinhold, 1962) p. 16.
30. A. PETERLIN, *J. Polymer Sci. C* **32** (1971) 297.

Received 7 August and accepted 24 October 1974.